



E9941 Flexi Pan



Short Form Specification

Unit to be Falcon F900 Series high performance electric vario pan. Pan will be 304 grade stainless steel. Unit to be supplied upon adjustable feet.

Unit will provide means of multipurpose cooking including griddling, boiling, braising and steaming. The cabinet will feature an easy to clean internal wrap with radiused bends and an integrated drain will facilitate easy emptying of the pan.

The hob will be constructed from 2mm 304 grade stainless steel. Hobs will be laser cut with right-angled edges to allow joining of units with no gaps between hobs. Exterior panels are Scotch Brite finish stainless steel. Control knobs to be marked showing temperature positions with a bezel behind control knob to prevent water ingress. Dedicated control panel symbols indicate the means of optimum performance.

Key Features

- 12 litre capacity - manual fill
- 60 - 280°C operating temperature range
- Pan accommodates 1/1 gn x 100mm container
- 1/1 gn x 200mm pan supplied with handles for ease of draining
- Multifunctional cooking
- IPX5 rated
- Supplied upon adjustable stainless steel feet
- 2mm thick 304 grade stainless steel hob
- Laser cut hob allows edge to edge joining of units
- Stainless steel external panels with Scotch Brite finish
- Dynamic Link System Compatible



Integrated linking system allows gap free installation to create a seamless, continuous cookline.

UK Patent No. 2540131

Optional Accessories

- Castors
- Front and side kick strips
- Steaming tray and lid
- Lid
- Side hob extension
- Front hob rail



E9941 Flexi Pan

Model Dimensions (mm)

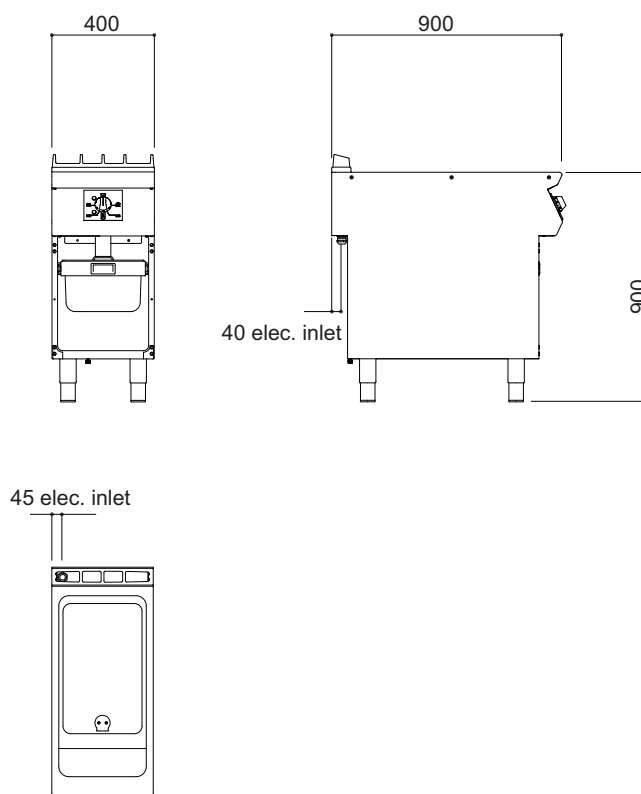

Specification Details

| | |
|--------------------------------|-----------------------------------|
| Electrical rating (kW) | 7 |
| Electrical supply voltage | 400V 3N~ 50/60Hz |
| Required electrical supply (A) | 32 |
| Element rating (kW) | 2.33 |
| Electrical current split (A) | L1: 10.14 , L2: 10.14 , L3: 10.14 |
| Capacity (litres) | 12 |
| Packed dimensions (mm) | 490 (w) x 1000 (d) x 1015 (h) |
| Weight (kg) | 66 |
| Packed weight (kg) | 76 |

Installation Note:

Please consult local legislation with regard to installation of cooking equipment.